

## POST AND FRAME STRUCTURES (Pole Barns)

**Post and frame structures.** The following requirements serve as minimum standards for post and frame structures within all of the following structural limitations:

1. Residential accessory structures
2. Single story
3. Metal roof on purlins with bracing and metal wall panels on girts, with bracing, or in lieu of bracing provide solid exterior structural sheathing
4. No attic storage
5. Maximum building width of 36 feet (provide engineer's review for structure if more than 36 foot in width)
6. Maximum wall height of 16 feet (provide engineer's review for structure over 12 foot and above in height)
7. Maximum "mean" roof height of 20 feet
8. Maximum post spacing of 8 feet

Post and frame structures and portions thereof outside the above structural limitations of this standard shall be accompanied by structural calculations as required by the residential building official or shall comply with the structural design requirements of section R301.1.3 of the 2015 Michigan Residential Code.

**Definition.** Post and frame structures consist of primary members (posts, beams and single span trusses or ceiling joists and rafters) and secondary members (roof purlins, wall girts, bracing and sheathing) where all loads are transmitted from the sheathing and the secondary members to the primary members which transfer them to the ground through vertical posts bearing on footings embedded in the soil.

**Footings & Foundations.** Footings and foundations shall comply with applicable provisions of Section R401 of the 2015 MRC. Post frame structures shall have poured in-place concrete footings installed below all posts. The top of the footing shall be a minimum of 42 inches below finished grade and have footing diameters complying with the following tables based on soil conditions at the site and calculated weight bearing on the posts.

GW, GP soils (Sandy gravel and/or gravel) Soil bearing capacity = 3,000 psf.

Hole dia.	Equiv. s.f.	Allow. bearing (lbs)
12" dia.	.785 sf.	2,335
16" dia.	1.395 sf.	4,185
18" dia.	1.766 sf.	5,298
20" dia.	2.18 sf.	6,540
24" dia.	3.14 sf.	9,420
28" dia.	4.273 sf.	12,819

*Tables continued page 2*

SW,SP,SM,SC,GM and GC soils (sand, silty sand, clayey sand, silty gravel, and clayey gravel) Soil bearing capacity = 2,000 psf.

Hole dia.	Equiv. s.f.	Allow. bearing (lbs)
12" dia.	.785 sf.	1,570
16" dia.	1.395 sf.	2,790
18" dia.	1.766 sf.	3,532
20" dia.	2.18 sf.	4,360
24" dia.	3.14 sf.	6,280
28" dia.	4.273 sf.	8,546

CL, ML, MH and CH soils (Clay, sandy, silty clay, clayey silt, silt and sandy siltclay) Soil bearing capacity = 1,500 psf.

Hole dia.	Equiv. s.f.	Allow. bearing (lbs)
12" dia.	.785 sf.	1,177
16" dia.	1.395 sf.	2,092
18" dia.	1.766 sf.	2,649
20" dia.	2.18 sf.	3,270
24" dia.	3.14 sf.	4,710
28" dia.	4.273 sf.	6,409

**Math equation to size post footings**

Weight on footing ÷ soil bearing capacity = required square foot size for a square footing.  
 To convert to round: convert sq. ft. to inches by multiplying the square footing size x 144.  
 Take the square inches of the area and divide by 3.14159. Take the square root of the result. This is the radius. Multiply the radius by 2 to get the required diameter of the round footing.  
 Minimum footing thickness should be 1/2 of the footing diameter unless calculations are provided.

**Example:** 9,429 lbs ÷ 1,500 = 6.28 sq. ft. x 144 = 904.32. ÷ by 3.14159 = 287.85. The  $\sqrt$  of 287.85 is 16.96 inches. This is the radius. 16.96 inches x 2 = 33.94 inches = required footing diameter.

**Column and wall construction.** Columns shall be three (3) ply unspliced, reinforced spliced or solid wood and shall not be less than 6 inch by 6 inch nominal size. Columns shall comply with the requirements of Section R317 of the 2015 MRC (Protection of Wood) and shall be restrained to prevent lateral displacement.

**Column uplift protection:** Columns shall have uplift protection by one of the following methods:

1. Two 2x6x12 inch column uplift protection blocks attached to each side of the base of the column. The column uplift protection blocks must be placed horizontally, attached per Table 5 and comply with Section R317.
2. 12 inch high, concrete collar poured on top of footing around the post, with 2-#5x9 inch rebar placed through the post at 3 inches and 9 inches from bottom of post in opposite directions. The rebar ends shall be installed in accordance with

ACI 332 for the specified distance in inches from contact with the soil. See Figures 1 and 2 on following pages.

# EXAMPLE CROSS SECTION

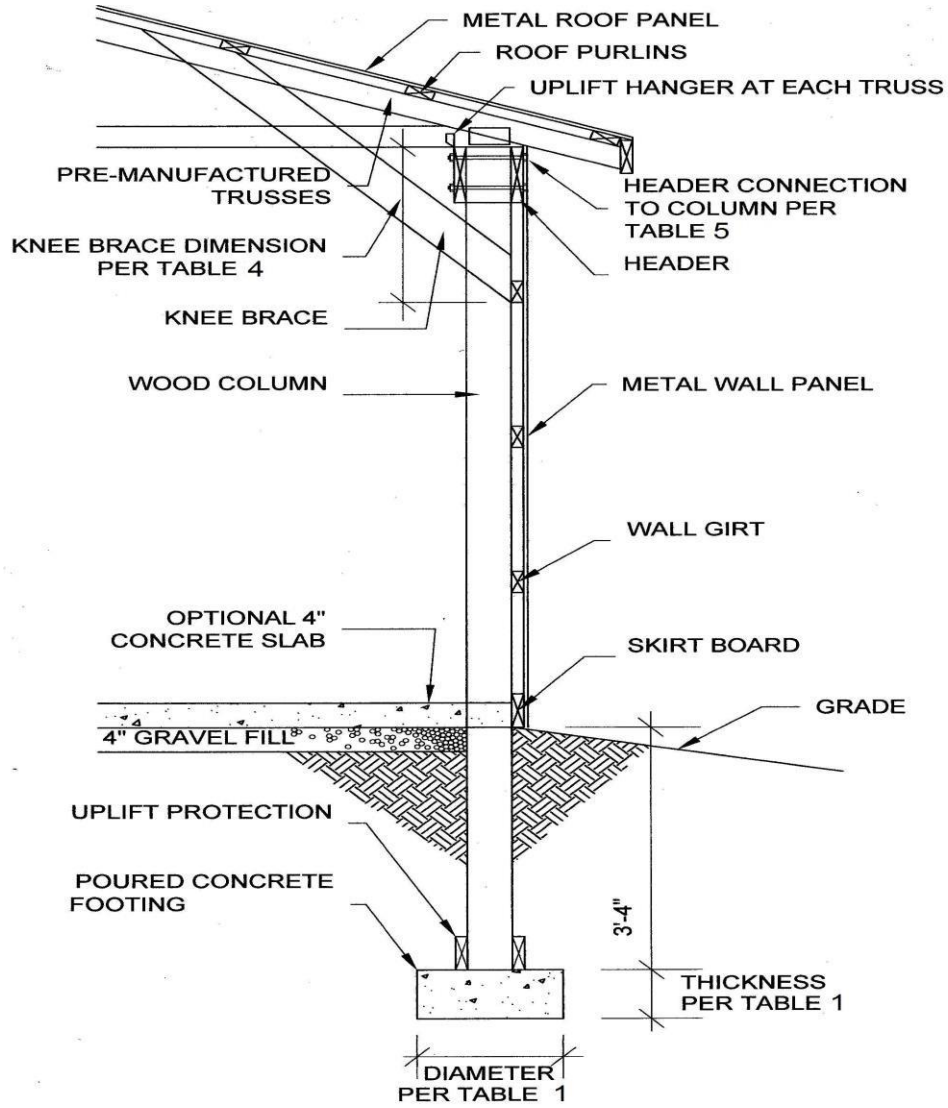

Figure 1  
Post and frame wall section.  
No scale

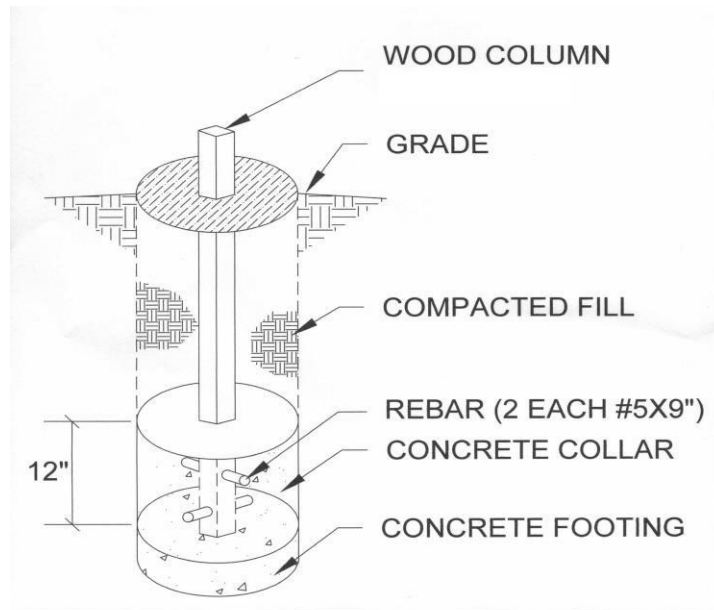
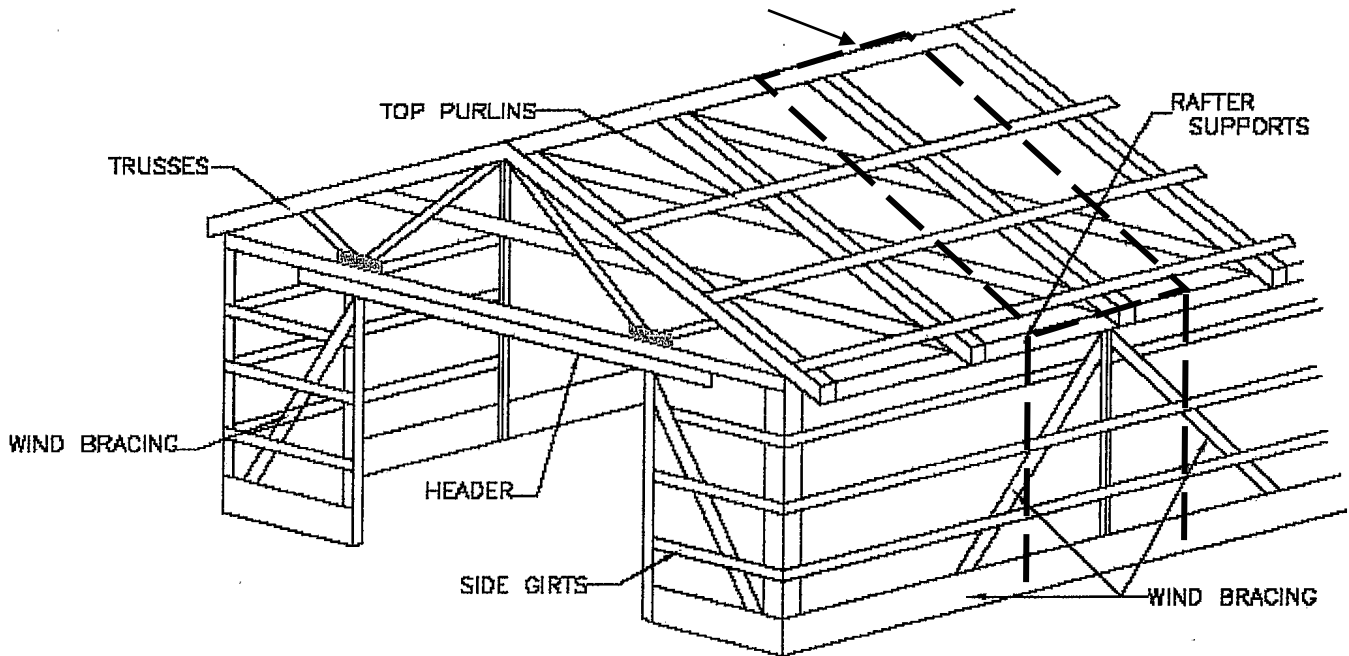

Figure 2

### TYPICAL POLE BARN STRUCTURE

A=area (sq. ft.)



Figuring calculated loads on footings is based on the square foot area  $\frac{1}{2}$  the distance between the posts and the roof area directly above. Calculated snow loads (25-35 psf) + roof dead weight (20 psf) + wall dead weight (15 psf). Example: 30 psf snow load + 20 psf roof load + 15 psf wall load x Area (120 snow= 3,600 + 120 roof=2,400 + 96 wall = 1,440) for a total of 7,440 on each post. Posts would need to be sized accordingly. Footings sized accordingly or reduce distances between posts to reduce calculated loads on posts and footings based on soil conditions.

**Column spacing.** The maximum spacing for columns shall be 8 feet.

**Skirt boards.** Skirt boards shall be treated lumber meeting the requirements of Section R317 and attached per Table 5.

**Wall girts:** Girts shall be a minimum 2x4 spaced not more than 24” on center and attached per Table 5.

**Load bearing beams and headers:** Load bearing beams and headers shall comply with Table R602.7.1 of the 2015 MRC.

**Exception.**

1. Bearing beams are not required if the trusses or ceiling joists and rafters bear directly on the columns.
2. Openings on the gable end walls of post and frame buildings supporting a door or roof total load not exceeding 5 square feet per lineal feet of wall area, headers must be sized per Table 2.

**Table 2 Gable end header sizes**

Opening Width (feet)	10	12	16
Header Size (inches)	2-2x8	2-2x10	2-2x12

**Exterior Structural Sheathing or Wall Bracing.**

Provide exterior structural sheathing or wall bracing to resist all racking and shear forces. Bracing must comply with the applicable provisions of section R602.10 of the 2015 MRC or by installing 2x6 diagonal braces between two adjoining columns at 8 feet on center. The diagonal brace shall be placed from the top header or girt to the next adjoining column at the skirt board. The bracing shall be placed installed on each side of the building and shall be a minimum of 25 feet on center and within 12 feet of the end of the building and attached to the wall girts and columns per Table 5. Any splices of the diagonal brace required due to excessive length, must lap over two consecutive wall girts.

**Roof Construction.** Top chord of roof trusses or roof rafters shall be braced with exterior sheathing or metal roof on purlins with bracing.

**Roof Purlins.** Roof purlins shall be a minimum of 2x4 SPF #2 laid flat of spans up to a maximum of 4 feet.

**Attachment details.** Structural fastener details for post and frame buildings shall comply with Table 5.

**Table 5 - Fastener Schedule for Structural Members**

Fastener Schedule for Structural Members		
Description of Building Element	Number and Type of Fastener	Attachment type
Uplift blocking to column	5-16d Hot Dipped Galvanized	Each block
Skirt board to column	2-16d Hot Dipped Galvanized	Face nail
Wall girt to column	2-16d Hot Dipped Galvanized	Face nail
Diagonal bracing to column	2-16d Hot Dipped Galvanized	Toe nail
Diagonal bracing to skirt board	2-16d Hot Dipped Galvanized	Face nail
Diagonal bracing to wall girts	2-10d Hot Dipped Galvanized	Face nail
Knee brace to column	2-10d	Face nail
Knee brace to top chord of truss or rafter	3-16d Hot Dipped Galvanized	Face nail
Knee brace to bottom chord of truss or ceiling joist	3-10d	Face nail
Roof purlin to truss or rafter with span of 2' or 4'	2-16d	Face nail

**NOTE:**

The building codes do not specifically provide for pole barn construction. Kochville Township requires that pole buildings that are greater than 12 feet in height and/or with trusses greater than 36 feet in width shall be required to be an engineered building and require an engineer's review and seal in order to obtain a building permit.

POLE BARN STRUCTURE FORM TO BE COMPLETED AND RETURNED WITH BUILDING PERMIT APPLICATION AND CONSTRUCTION PLANS.

**POLE BARN SPECIFICATIONS**

**HEIGHT OF SIDEWALLS:** \_\_\_\_\_ **MEAN HEIGHT OF STRUCTURE TO GRADE:** \_\_\_\_\_

**MINIMUM FOOTING DEPTH:** 42 inches

**FOOTING SIZE:** \_\_\_\_\_ (From specifications as provided in this handout or from engineered drawings, if required).

**CONCRETE:** Minimum 2500# concrete must be used for footings. Concrete must be a wet mix concrete from an approved supplier except where pre-cast concrete "cookies" are allowed as provided for in this handout.

**POSTS:** \_\_\_\_\_ (From specifications as provided in this handout or from engineered drawings, if required).

**TRUSS CARRIER SIZE:** \_\_\_\_\_ (From specifications as provided in this handout or from engineered drawings, if required).

**TRUSSES:** Provide copy of truss diagram with construction plans.

**ROOF COVERING:** Asphalt Shingles \_\_\_\_\_ Purlins and Steel Panels \_\_\_\_\_

**OVERHEAD DOOR OR SLIDER DOOR LOCATION:**

Gable [  ] Eave [  ] Width of overhead door \_\_\_\_\_

**INTERIOR FINISHES:** \_\_\_\_\_

None [  ] Note: Exposed rigid foam not allowed. Foam insulation must be covered by a thermal barrier, such as ½ inch drywall.

**MECHANICAL:** \_\_\_\_\_

None [  ] Solid fuel burners are not allowed.

Floor drains, if installed, must drain to open air and not under the concrete slab, if installed.

Submission: Mandatory

Penalty: Permit will not be issued.